

hidroconta
metering technology

WHEN WATER COUNTS



water meter

centAURUS

SERIE 100

Made in Spain

hidroconta.com

Single jet metering system

Electronic water meter with **mechanical body**

Autonomy
15 years

Starting flow
from 5 l/h

Protection
IP68



Communications included
NB-IoT/WM-Bus

High accuracy
R200H

Adjustable display

Installation
U0/DO

REV.7

Smart water meter

CENTAURUS records water consumption in real-time. Access to recorded data by daily, weekly, or monthly patterns through our SOFTWARE solution.

Receive just-in-time leaks, tampering or clogging alerts. CENTAURUS sends an instant alert to take immediate action. Due to its high accuracy, the smallest leaks are now detectable. Avoid unnecessary waste thanks to predictive maintenance.

Our SOFTWARE solution includes DMA performance analysis. Access to a daily updated WATER BALANCE of your network.

CENTAURUS Series.
The smart water meter designed by HIDROCONTA in Europe.

Homologation MID

Hidroconta's Centaurus water meter has the metrological requirements based on the Directive 2014/32 / EU, so they are normally used for the totalization and control of domestic water consumption. In Hidroconta we make strict tests in the counters that assure its quality and its precision.

Technical specifications

- ✓ Temperature range T30.
- ✓ Copper alloy body.
- ✓ IP68 sealed electronic totalizer.
- ✓ The electronic totalizer can be rotated manually, for a reading in any position.
- ✓ MID approval for potable water. Directive 2014/32 / EU.
- ✓ Straight sections are not necessary at the meter input or output U0-D0.
- ✓ Single jet metering system.

Dial marking



Water meter manufacturer and model

Accepted communication protocols

Rango de trabajo
 MID approval for drinking water
 Certifying center

Permanent flow value

Working range

Year of manufacture

Alphanumeric display

Meter serial number
 Maximum working pressure
 Installation conditions
 Degree of protection

Software Version



Battery status

Registered water volume

Flow direction

Alarms

Registered instantaneous flow

Disassemble



Nº	DESCRIPTION	MATERIAL
1	Cover	Polycarbonate
2	Casing body	Polycarbonate
3	Crystalline casing	Polycarbonate
4	PCB and Display	Assembly
5	Battery case	Polycarbonate
6	Batteries	Li-Ion
7	Inductive sensor	Assembly
8	Casing base	ABS
9	Anti-fraud ring	Iron
10	Anti-fraud ring	Iron
11	Plate + separation ring	Plastic
12	Helix	Plastic + magnet
13	Water meter body	Copper alloy

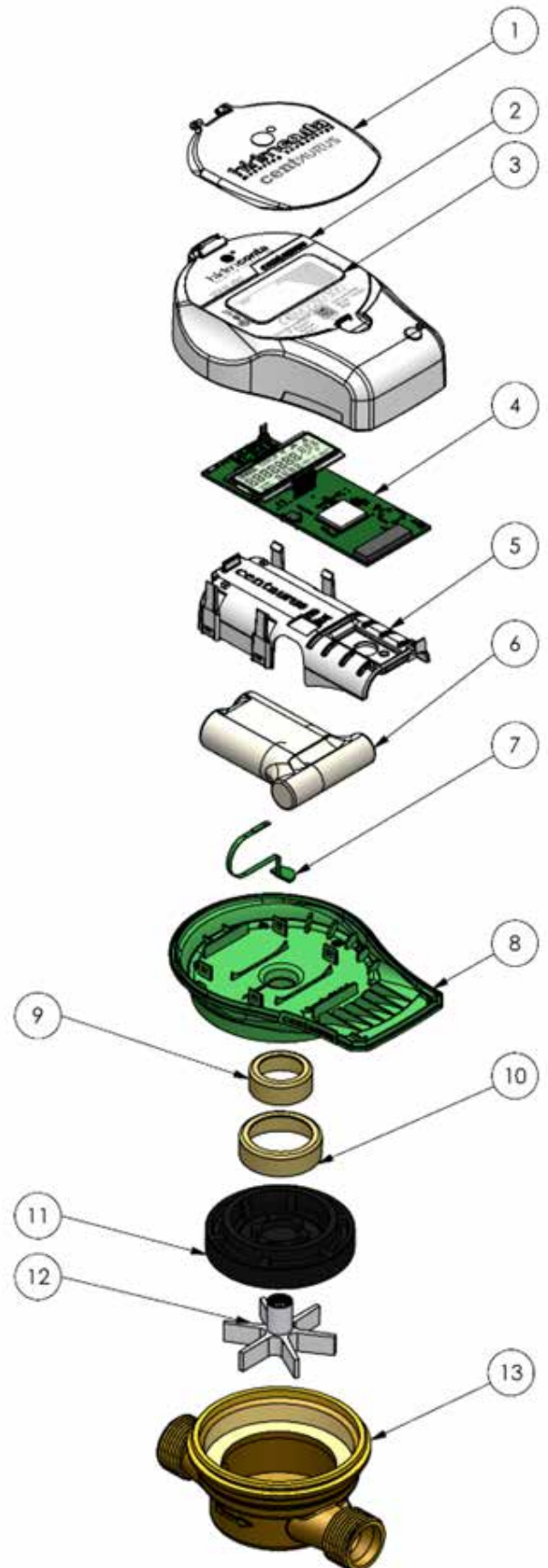

Dimensions

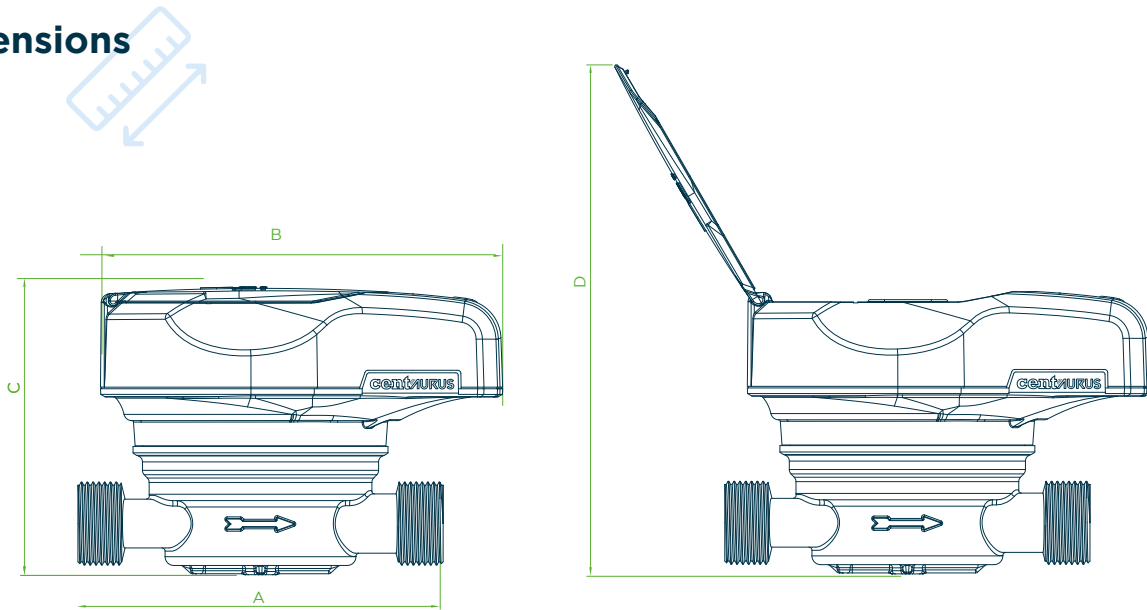

DN	A	B	C	D	WEIGHT WITHOUT COUPLING	THREADED CONNECTIONS	
mm	in	mm			Kg		
13	1/2"	115	130	90	160,5	0,40	G 7/8" x 3/4 BSP
15	1/2"	115	130	90	160,5	0,41	G 3/4" BSP
20	3/4"	130	130	90	160,5	0,51	G 1" BSP

Packing



DN	UNITS PER BOX	BOX DIMENSIONS (cm)			GROSS WEIGHT
		Largo	Ancho	Alto	
DN13	1	16	10	14	0,5
DN15	1	16	10	14	0,5
DN20	1	20	15	16	0,6

Diagrams for installing

- ✓ For the installation of Centaurus serie 100 straight sections are not necessary in the input or output.

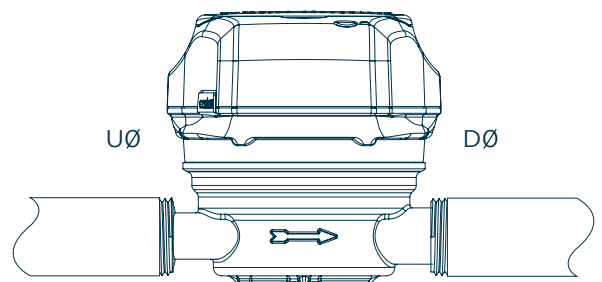

Working conditions

ROOM TEMPERATURE

-10 °C ~ 55 °C

MAXIMUM PRESSURE

≤ 16 bar

Maximum permissible error

RANGE

$Q_1 \leq Q < Q_2$

ERROR (%)

± 5%

$Q_2 \leq Q \leq Q_4$

± 2%

Technical specifications

DN		Q ₄	Q ₃	Q ₂	Q ₁	STARTING FLOW RATE	MINIMUM READING	MAXIMUM READING	RATIO
mm	in	m ³ /h		l/h		l/h		m ³	
13	1/2"	3,125	2,5	20 100	12,50 62,50	5	0,001	9.999.999	R200H R40V
15	1/2"	3,125	2,5	20 100	12,50 62,50	5	0,001	9.999.999	R200H R40V
20	1/2"	5	4	32 160	20 100	6	0,001	9.999.999	R200H R40V

Pressure loss curve

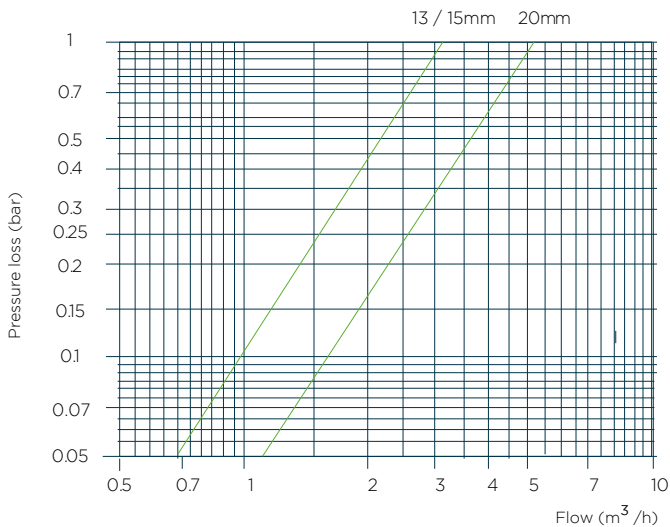

Flow error curve

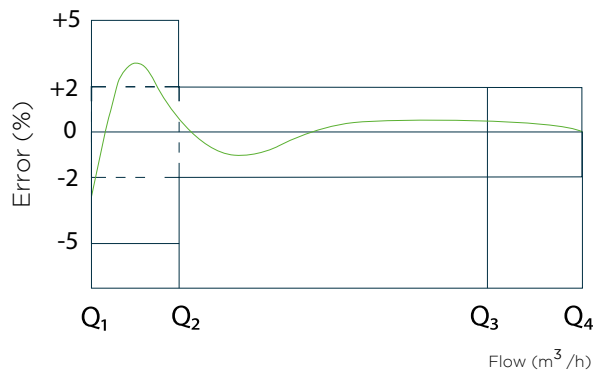

Communications

- **Short range communications 868 MHz.** Wireless communication port for local connection to the device for maintenance/configuration tasks.
- **NB-IoT for long-range communications**
- **wM-Bus for walk-by/drive-by communications or fixed network**

Automatic reading water meter

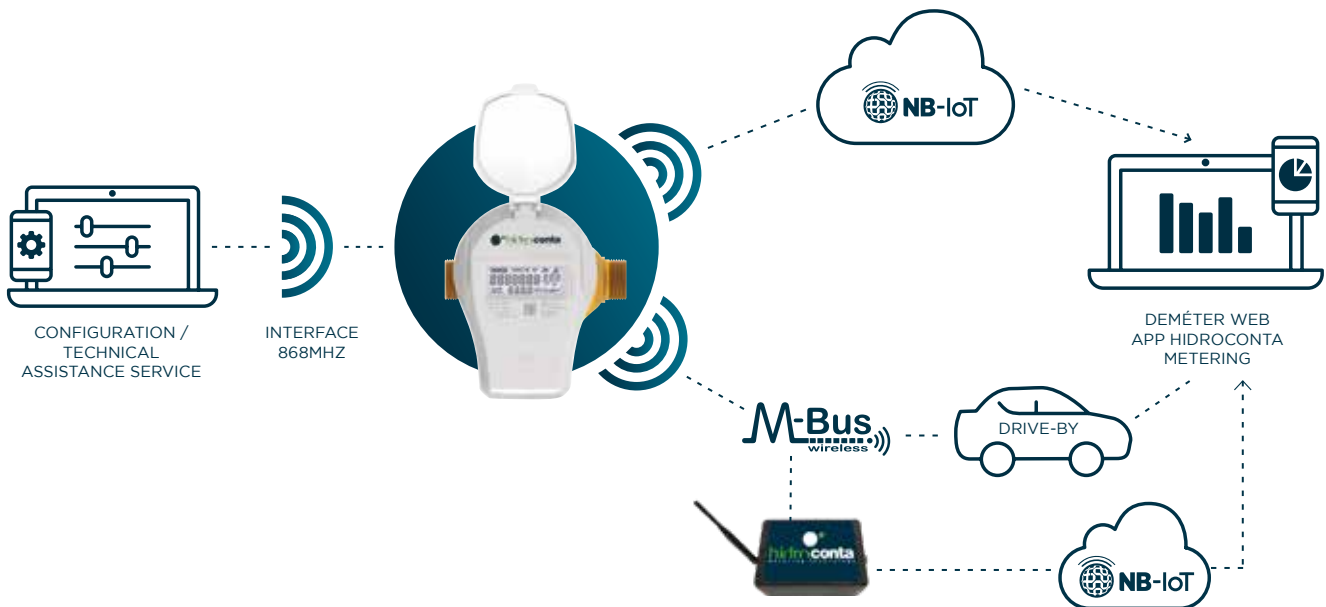

NB-IoT		WM-Bus	
Bands	B8 / B20	868 MHz	
Transmission power	23 dBm +/-2dB	OMS T1 and C1	
Firmware Update	Via FOTA		



Alarms

Historical values

The hourly, daily and monthly values of the measured parameters are stored in internal memory.

The recorded data can be read remotely.

Data register

- Total volume.
- Hourly, daily and monthly volume.
- Engineering parameters of the NB-IoT connection.
- Alarms.

Reverse flow alarm:

Reverse flow detection. If there is flow in the reverse direction the alarm is triggered.

Set the amount of liters to trigger the alarm.

Leak alarm:

Occurs when constant flow rate is higher than a specific flow (time and flow are customizable values).

HIDROCONTA recommends to set it up 0.5% Q3.

No consumption alarm:

Occurs if the detected flow rate is zero for a certain period of time (customizable).

Under Dimensioned alarm:

Occurs when the average flow rate is higher than a custom value during a certain customizable period of time.

Over Dimensioned alarm:

Occurs when the average flow rate is lower than a custom value during a certain customizable period of time.

Burst alarm:

Occurs when a customized constant flow rate is higher than a specific flow for a short period of time

HIDROCONTA recommends to set it close to Q3.

Excessive flow alarm:

Occurs when an instant flow rate is higher than a custom flow value.

HIDROCONTA recommends to set it close to Q4.



Alarms notice on the display

In the event that one or more alarms occur, they will be shown on the display instead of the flow rate digits, alternating with it as follows:

A capital "A" will appear in the leftmost digit indicating that there are active alarms (or already past but not reported).

The remaining 3 digits will show which alarms exist, each digit will report alarms as follows.

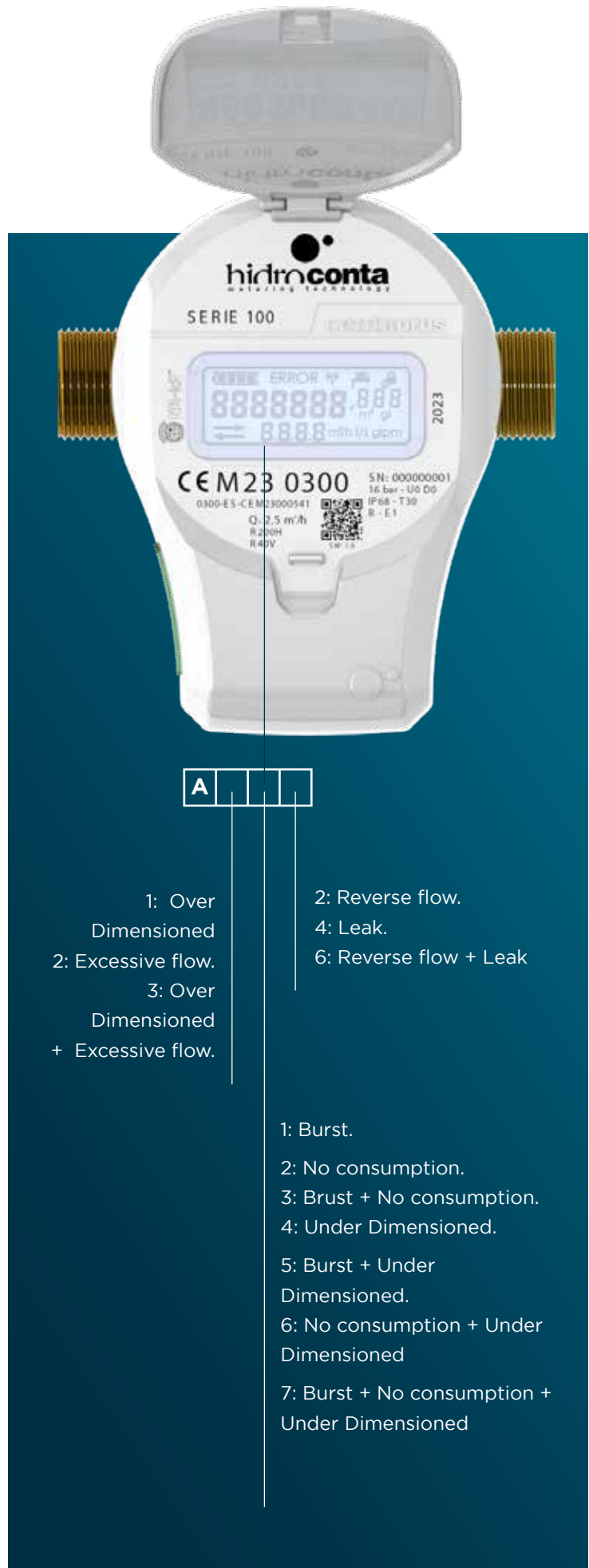

- 1: Over Dimensioned
- 2: Excessive flow.
- 3: Over Dimensioned + Excessive flow.

- 2: Reverse flow.
- 4: Leak.
- 6: Reverse flow + Leak

- 1: Burst.
- 2: No consumption.
- 3: Burst + No consumption.
- 4: Under Dimensioned.
- 5: Burst + Under Dimensioned.
- 6: No consumption + Under Dimensioned
- 7: Burst + No consumption + Under Dimensioned

REV.7

Functionality



Operation timed by a real-time clock periodically synchronized by an external clock source. Communications according to scheduled programming or commanded by an operator in person. Temporarily scheduled communication supports:

- ✓ Up to 8 registration windows within a day of operation. Specifying the start and end time of the period and the recording interval (minutes).
- ✓ Up to 8 daily transmission windows. Allowing to specify start time of the connection.
- ✓ Standardized operating profiles based on the requirements for registering historical consumption and communications.
 - Normal-24: Sending data every 24 hours and recording every hour.
 - Normal-8: Data sending every 8 hours and recording every hour.
 - Medium: Sending data every 12 hours and recording every 30 minutes.
 - Extreme: Sending data every 6 hours and recording every 15 minutes.

MODE	AUTONOMI	COMMUNICATION	HISTORICAL
Normal -24	15 years	24 h	1 h
Normal -8	11 years	8 h	1 h
Medium	13 years	12 h	30 min
Extreme	10 years	6 h	15 min

REV7

Installation instructions

The meters must always be full of water when operating, minimum pressure 0,3 bar, and installed below the slope of the rest of the pipeline. This stops air pockets from forming inside.

If there is air in the pipeline, suckers must be fitted to avoid incorrect readings. If the water in the pipeline contains large suspended particles, an initial screening filter should be installed.

Fit a valve upstream from the meter to facilitate maintenance or repair.

A new pipeline should be drained before fitting a meter to eliminate particles.

Do not force the meter during assembly; avoid tension or torsional stress, especially to the threaded connections.

Once the physical installation of the water meter has been completed, the same must be completed by adding the geolocation of the same in the server.

This step will be done using an application (APP) for mobile devices as a tool. The "Centaurus Connect" application.



1. What are the ranges of measurement and precision?

The measuring range of the meters is determined by the Directive MID 2014/32 / UE establishing the ratio between the value of the permanent flow (Q3) and that of the minimum flow (Q1). The water meter can measure up to the maximum flow rate (Q4) for short periods of time without deterioration.

The maximum permissible error, positive or negative, in volumes between the transition flow (Q2) (included) and the overload flow (Q4) would be 2% with a water temperature 30 ° C.

The maximum permissible error, positive or negative, in volumes between the minimum flow rate (Q1) and the transition flow (Q2) (excluded) would be 5%.

2. The MID directive and its compliance

The MID Directive (2014/32 / EU Measuring Instruments Directive) is a directive of the European Union whose purpose is to harmonize the di

erent aspects of Legal Metrology in the member states.

The most important aspect of this directive is that equipment in possession of a MID certificate can be used in the EU.

hidroconta
metering technology

WHEN WATER COUNTS

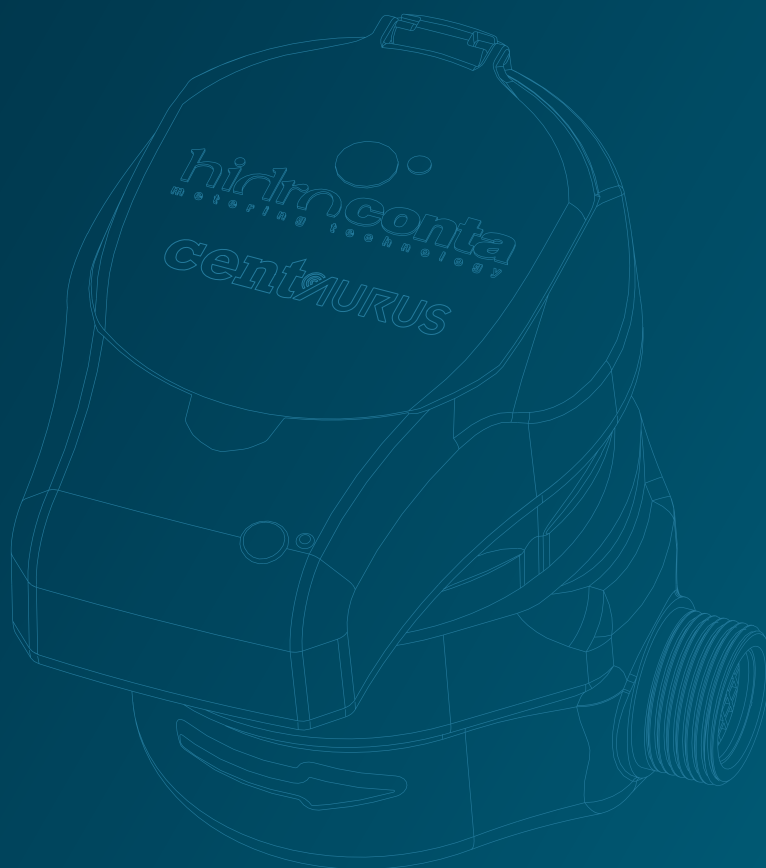

water meter

centaurus

SERIE 100

Ctra. Sta Catalina, 60
Murcia (30012) España

T: +34 968 26 77 88



ER-0362/2000



Hidroconta declines all responsibility for errors in the information contained in this document, which may be modified without prior notice. All rights reserved. Copyright. 2021 HIDROCONTA, S.A.U.

Made in Spain

hidroconta.com